

# SCDC DIAGNOSTIC SOFTWARE

## SCDC CNTRL USB ver 2.exe

### Instructions #7267

The SCDC Diagnostic Software kit gives you the capabilities listed below. The following Instructions apply to both the Pay-Out and Rewind Cards.

### Table of Contents

Software Installation	1-2
Pixel Test	3
Software Upgrade	3-4
Eeprom Values	4
Logged Error Data	5
Unit Test	5
Trouble Shooting	6-8

---

### CABLE REQUIREMENTS

Computer	SCDC Board	
USB port	USB Interface	Use USB cable type A (m) to type B (m)
RS232 serial port	Serial Interface	Serial cable Part no. 4626
USB port	Serial Interface	Serial cable Part no. 4626 and USB to Serial adapter (see PIB 7162 For help with selection of adapter.)

Minimum system requirements are Windows 98, NT or XP and a USB port.

### SOFTWARE INSTALLATION

**Note:** If the computer being used has other USB enabled software already installed, it may be necessary to uninstall those, then install SCDC CNTRL USB ver 2.exe, and then reinstall the other software. This software can be used with both the USB and Serial interface SCDC controls.

Software Installation (continued)

1. Copy the file SCDC CNTRL USB ver 2.exe from the floppy or CD to any folder on the hard drive.
2. Run the file from the hard drive. You should get the following screen:

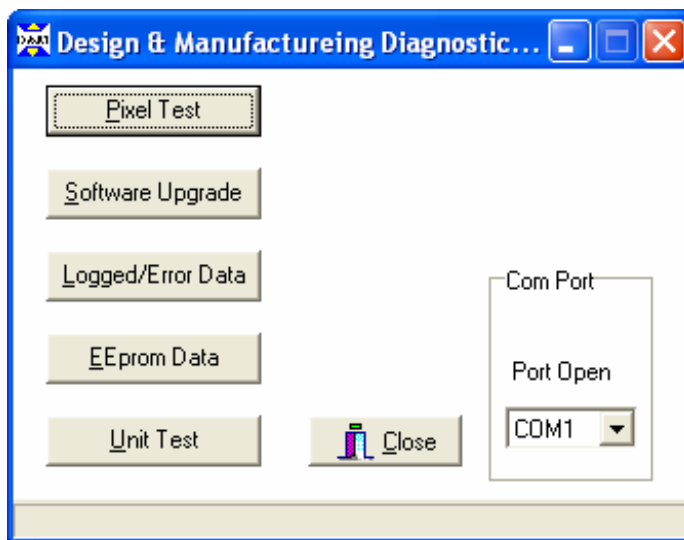

Figure 1

3. Plug the "A" (m) end of the USB Cable into the computer and select that com port. The software remembers the last com port used and defaults to that port.
4. Plug the "B" (m) end of the USB Cable into the SCDC card next to the Red LED as shown below. The port on the Rewind card is in the same location as the Pay-Out Card but does not have the black cover.

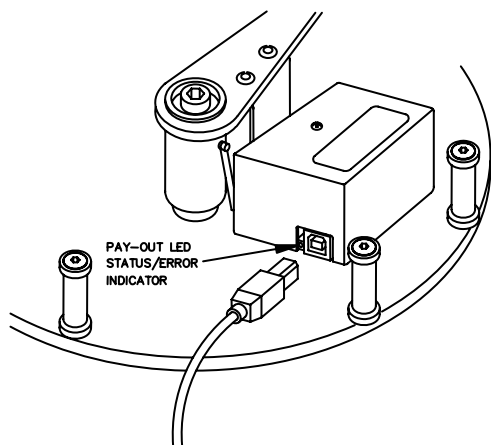

Figure 2

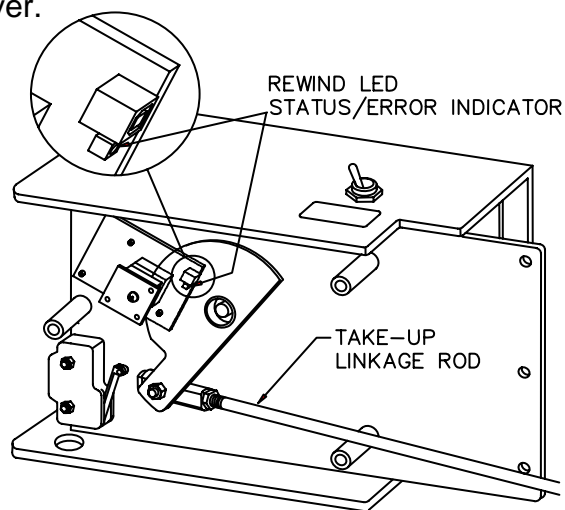

Figure 3

## PIXEL TEST

(Read only)

This Pixel Test display (figure 4) shows the number of pixels covered by the Control Plate Mask or the Rewind Sensor Disk as it moves through the Pay-Out or Rewind Card. When the card is positioned correctly, a maximum of 249 pixels and a minimum of 6 pixels are covered as the mask moves from one extreme to the other. The Pay-Out or Rewind Card can be adjusted slightly to read the correct pixel count by loosening the three mounting screws and repositioning the card.

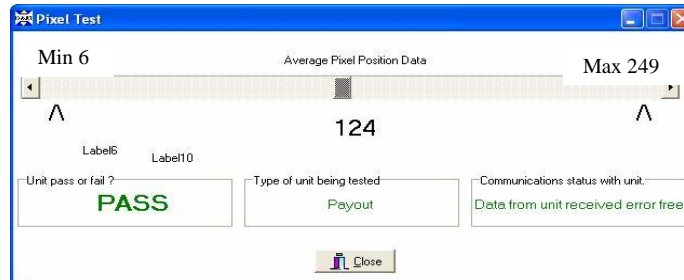

Figure 4

## SOFTWARE UPGRADE

(Write only)

1. Open the SCDC software.
2. Pick the Software Upgrade Button (figure 5).

**Note:** Do not run the platter system during Software Upgrade. Attempting to do so will cause the program to shut down. All tests can be done while the platter system is in operation

3. Pick the Version 2.0 USB Button (figure 6).
4. Download screen appears and when the download is complete pick the OK Button. (It will take approximately 2 minutes to load the new software)
5. Pick the Close Button.

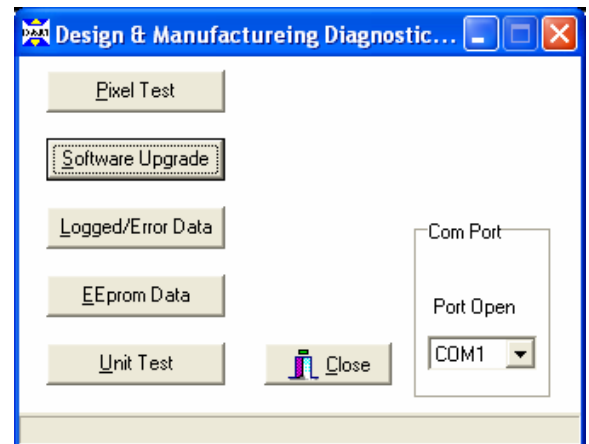

Figure 5

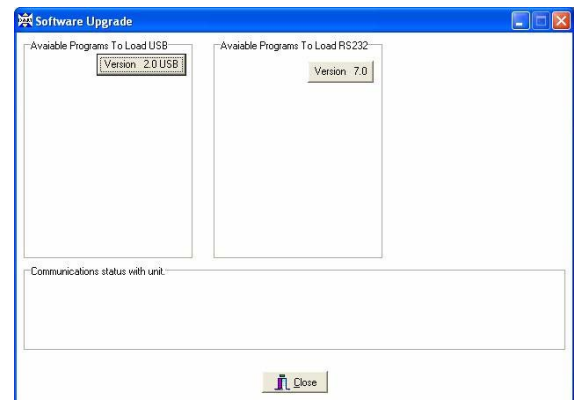

Figure 6

Software Upgrade (continued)

6. Pick the Eeprom Data Button (figure 5).
7. Pick the Reload Defaults Button (figure 7).
8. Compare the values to the chart below.

The software updating is now complete.

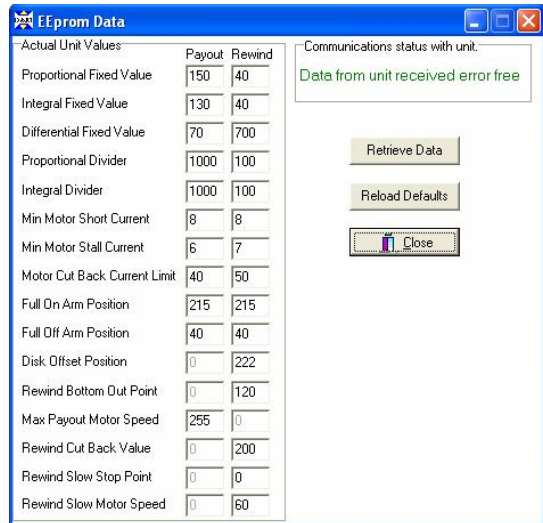

Figure 7

<b>PAYOUT</b>	<b>VER 7</b>
<b>SCDC</b>	
PROPORTIONAL FIXED VALUE	150
INTEGRAL FIXED VALUE	130
DIFFERENTIAL FIXED VALUE	70
PROPORTIONAL DIVIDER	1000
INTERVAL DIVIDER	1000
MIN MOTOR SHORT CURRENT	8
MIN MOTOR STALL CURRENT	6
MOTOR CUT BACK CURRENT LIMIT	40
FULL ON ARM POSITION	215
FULL OFF ARM POSITION	40
DISK OFFSET POSITION	0
REWIND BOTTOM OUT POINT	0
MAX PAYOUT MOTOR SPEED	255
REWIND CUT BACK VALUE	0
REWIND SLOW STOP POINT	0
REWIND SLOW MOTOR SPEED	0
<b>REWIND</b>	
<b>SCDC</b>	
PROPORTIONAL FIXED VALUE	40
INTEGRAL FIXED VALUE	40
DIFFERENTIAL FIXED VALUE	700
PROPORTIONAL DIVIDER	100
INTERVAL DIVIDER	100
MIN MOTOR SHORT CURRENT	8
MIN MOTOR STALL CURRENT	7
MOTOR CUT BACK CURRENT LIMIT	50
FULL ON ARM POSITION	215
FULL OFF ARM POSITION	40
DISK OFFSET POSITION	222
REWIND BOTTOM OUT POINT	120
MAX PAYOUT MOTOR SPEED	0
REWIND CUT BACK VALUE	200*
REWIND SLOW STOP POINT	0
REWIND SLOW MOTOR SPEED	60

\*This value changed to 255 for 70/225/52 and 35/336/52 operation

Note: A password is required to change any of the Eeprom Values. Contact Ballantyne's customer service.

## LOGGED ERROR DATA (Read only)

This Logged Error Data screen will report any current or logged error conditions and give some other statistical information. This display can also be used to monitor the current condition of the LED. This data can be printed by picking the print button. It will print to your default printer.

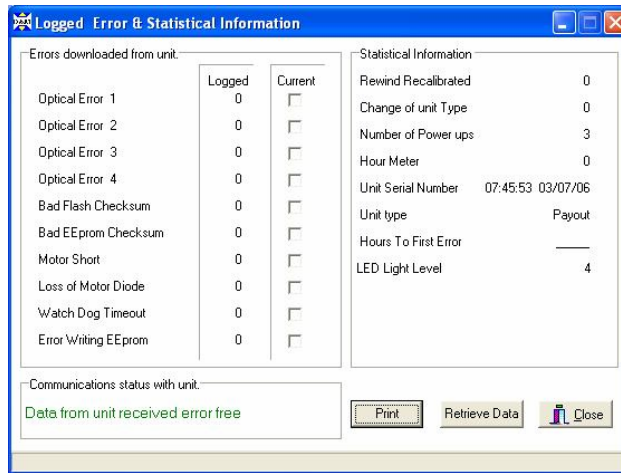

**Figure 8**

## UNIT TEST (Read only)

This Unit Test display (figure 9) gives you a visual electronic look at the unit at work. The com cable can be left connected to the card to view this display on a monitor if desired.

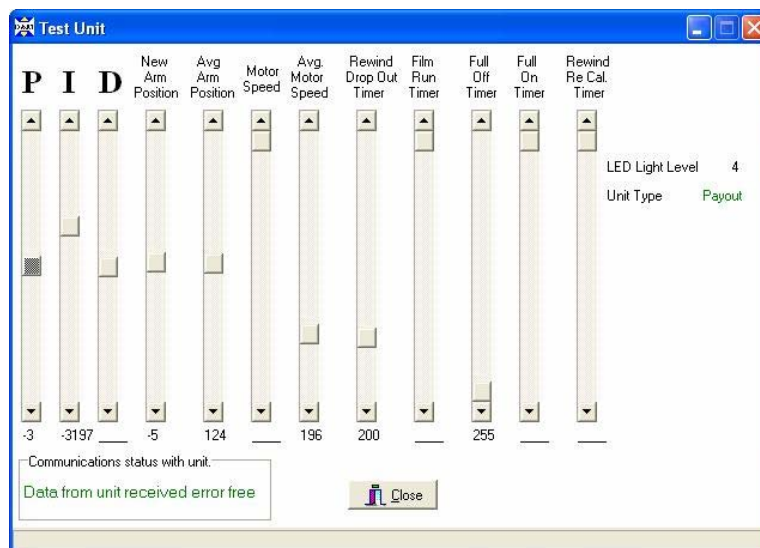

**Figure 9**

## TROUBLE SHOOTING

### SCDC LED ERROR INDICATION

The SCDC Rewind Card red indicator LED is visible through the opening on the back of the power supply case where the linkage arm travels (See location of LED in Figure 3). At power-up the red LED will blink a number of times equivalent to the version number of the software installed on the control. It will then begin **continuous fast blinking** if the control is operating properly.

The same LED is used to indicate errors. If an error occurs, it will appear on the error log screen with a check mark in the box of the current error. It will also be added to the logged error count, which is a permanent record. The current error field is cleared when the control is powered down. Error indication is as follows:

1. **One blink every two seconds** indicates that the motor or the feed castor diode is shorted. This error will log as a MOTOR SHORT on the logged error screen. See Feed Castor Diode Checking in Operation Manual PIB 4493 (page 6). Also unplug the suspect drive motor to isolate.

**Note:** If the motor or feed castor diode is defective, you should get the same error indication from both the Pay-Out and Rewind control used on that arm.

2. **Two blinks every two seconds** indicate an open Feed Castor Diode. This error will log as a LOSS OF MOTOR DIODE on the logged error screen. If you get this error, turn the power off and on again.

If the error is indicated a second time on a Pay-Out Control, plug the control into another arm. If the problem exists on only one arm, the problem is an open feed castor diode. The diode needs to be replaced. See Feed Castor Diode Checking in Operation Manual PIB 4493 (page 6).

If the error is indicated a second time on a Rewind Control, activate a different Rewind Feed Castor. If the problem exists with only one castor, the problem is an open feed castor diode. The diode needs to be replaced. See Feed Castor Diode Checking in Operation Manual PIB 4493 (page 6).

**Note:** If the feed castor diode is defective, you should get the same error indication from both the Pay-Out and Rewind control used on that arm.

3. **Three blinks every two seconds** indicate one of four possible optical errors. This error will log as OPTICAL ERROR 1-4 on the logged error screen. Optical error 1 and 2 indicate that the optical chip is either defective or improperly installed. This error detection was put into place primarily as a factory test to ensure that the optical chip has been properly installed and is not likely to occur in the field. However, if it does occur, review Service Bulletin #6802 before proceeding with any other corrections.

Optical error 3 and 4 indicate that the Pay-Out sensor mask or Rewind sensor disk is damaged or missing. If the mask or disk is installed correctly, a few pixels at the end of the row of pixels on the optical chip will be covered and a few pixels on the opposite end will never be covered. The operating system reads which end is covered and determines from that whether the card is installed as a Pay-Out or Rewind control.

Optical error 3 occurs when both ends of the pixels are seeing light all of the time. Verify that the Pay-Out sensor mask or Rewind sensor disk is installed correctly and undamaged.

Optical error 4 occurs when both ends of the pixels are not seeing light. Check the LED light level. See SCDC LED Failure Test below. If the LED has reached its fail point, an optical error 4 will be logged. This refers to the LED used to stimulate the optical chip, not the red indicator LED. Verify that the Pay-Out sensor mask or Rewind sensor disk is installed correctly and undamaged. This error can also occur if there is an obstruction between the LED and optical chip. Remove the LED board and remove any dust or lint that may be covering the optical chip.

Optical error 3 and 4 may also occur as result of an internal defect on the control. Replace the suspect Pay-out or Rewind control with a working control from another SCDC control plate or power supply. If the problem exists after changing the control, the mask or disk is defective. If the problem disappears after changing the control, the original control is defective and needs to be replaced.

4. **Four blinks every two seconds** indicate a bad check sum on flash or EEprom memory. If you get this error, turn the power off and on again. If the error is indicated a second time check the error log. If this error logs as BAD FLASH CHECKSUM, use the software upgrade function to install new software. If it logs as BAD EEPROM CHECKSUM, use the EEprom Function and reload defaults. If this fails to correct the problem, the control is defective and needs to be replaced.

### **SCDC LED FAILURE TEST**

The LED Board used in SCDC Pay-Out and Rewind Cards can lose its light intensity over time. In order to maintain the proper light intensity the voltage to the card increases. The amount of voltage required to make the card perform properly is represented by the Light Level Code, as viewed in figure 11. Each time the unit is powered up, the card updates this number based on the current condition of the LED.

Upon power up, if this number increases to 16, a pay-out control will cause the pay-out platter to run "full on". Under the same conditions, a rewind control will power down. It is recommended that the LED board be replaced any time the Light Level Code exceeds 13. This reading can be verified by following the following instructions.

1. Run the file from the hard drive. You should get the following screen:

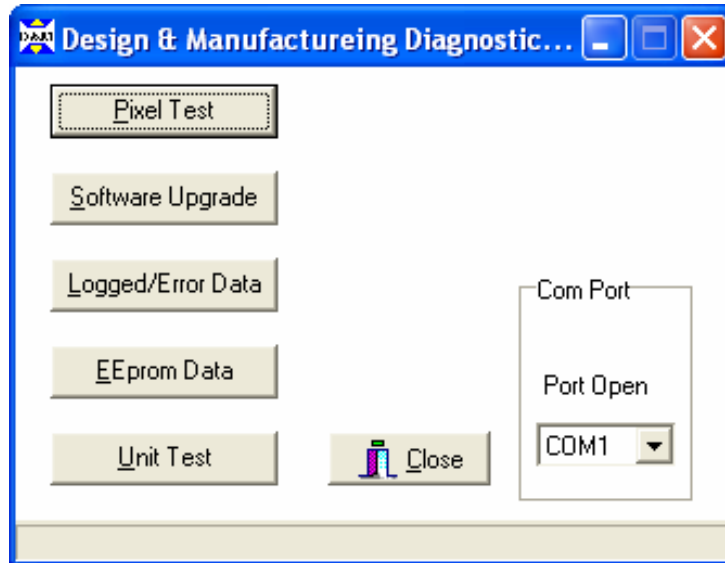

Figure 10

2. Select “Logged Error Data” Screen (shown in Figure 10). You will get the following screen:

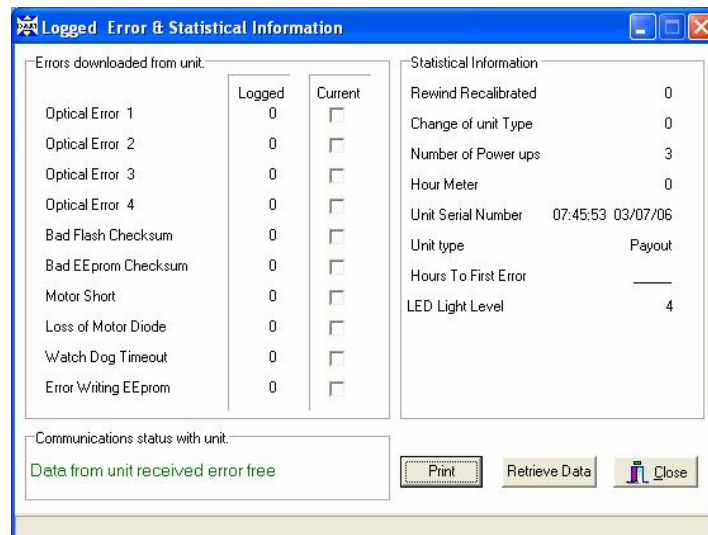

Figure 11

Note the “LED Light Level” number in the lower right corner of the screen. If this number is 13 or higher the LED board is near the fail point and it is recommended that the LED board be replaced. Check both the Pay-Out and the Rewind cards. A SCDC LED Replacement Board (part # 6329) can be used on both types of cards.