

# SKIMERATOR® MODEL 3717F SPECIFICATIONS

Basic system includes shallow draft extreme duty floating head skimmer Box with screen, air pump, reservoir with baffle assembly and weir box assembly, flow restrictor and all necessary hoses and fittings.

- Use in high temperature environments where coolant may exceed electric pump temperature limits, up to 180 degrees F.
- Use in sumps where coolant level fluctuates more than the range of a fixed mount skimmer box.
- Use in sumps with no room for a submersible pump or where compressed air power is preferable to electrical power. Air pump is not submersible.

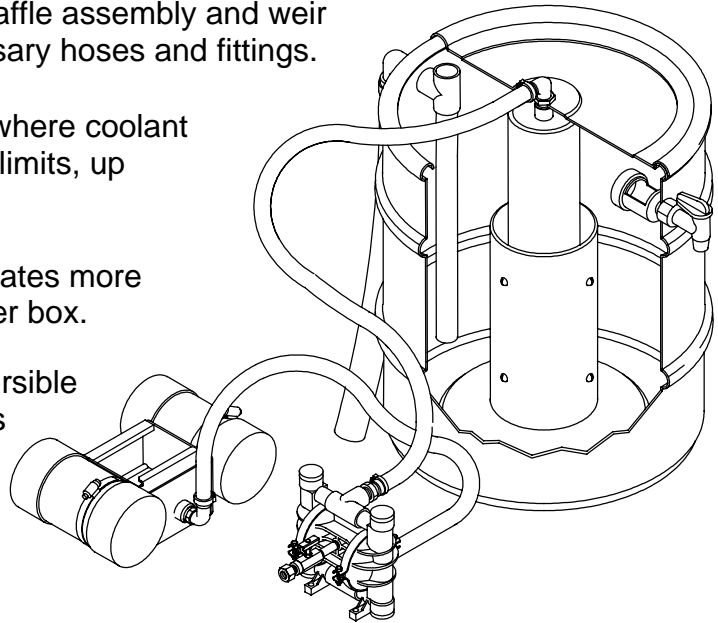

See Skimerator manual PIB 6540 for more information.

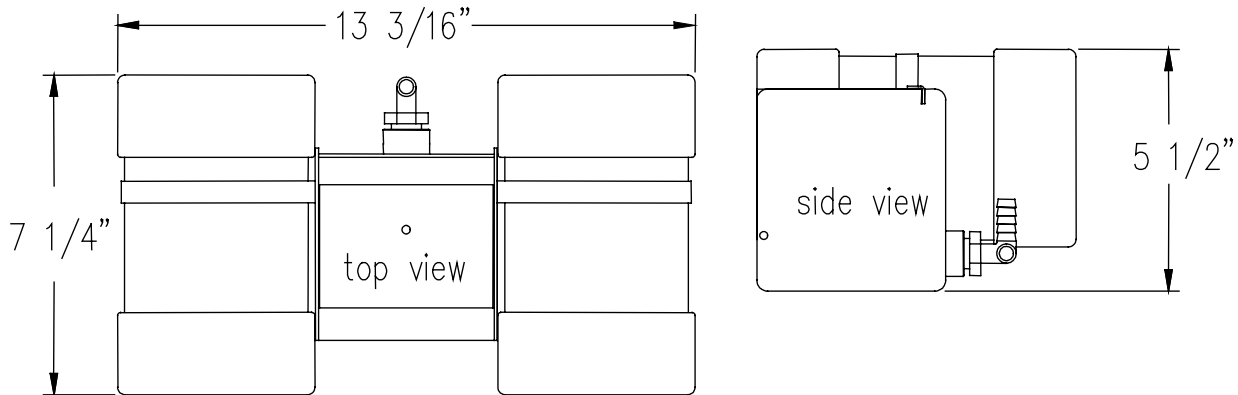

## FLOATING HEAD DIMENSIONS

Pump specifications	Polypropylene body w/ Teflon® diaphragms, Self priming
Pump capacity	Max. flow rate 4.8 gpm.
Reservoir	Translucent polyethylene, 15 gallon capacity, 16" dia x 21" high.
Warranty	12 months parts and labor

Manufactured in U.S.A. by:

**Design & Manufacturing, Inc.**

[www.design-mfg.net](http://www.design-mfg.net)  
or phone 800/236-9496

