

SKIMERATOR® MODEL 3200W SPECIFICATIONS

Basic system includes shallow draft skimmer box with screen, skimmer box stand, electric pump, reservoir with baffle assembly and weir box assembly, flow restrictor, all necessary hoses and fittings and skimmer stand with wheels.

- Use in sumps where the coolant level varies no more than 3"
- Accommodates a coolant depth of 1-1/2" to 4-1/2" (with skimmer box on the floor of sump) and 2-1/4" to 15-7/8" using the adjustable skimmer foot and 12" post.
- Stand with wheels allows reservoir with coolant to be moved between machines.

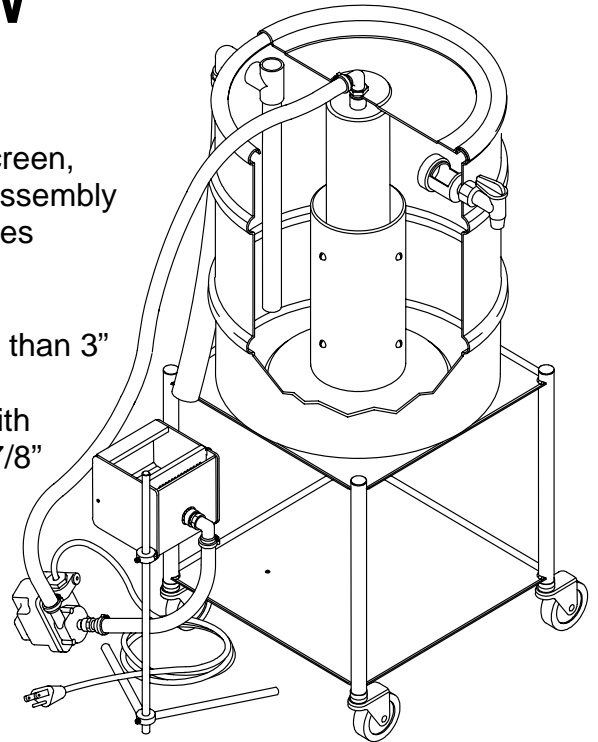

See Skimerator manual PIB 3241 for more information.

SPECIFICATIONS

Pump specifications	Submersible, epoxy encapsulated motor, 115v, 1/125 HP. 10' cord.
Pump capacity	100 GPH (5' height), to 140 GPH (3' height) @3 PSI, 120 deg. max.
Reservoir	Translucent polyethylene, 15 gallon capacity, 16" dia x 21" high.
Stand dimensions	14-5/8" x 14-5/8" x 16" tall.
Reservoir height on stand	37"
Warranty	12 months parts and labor

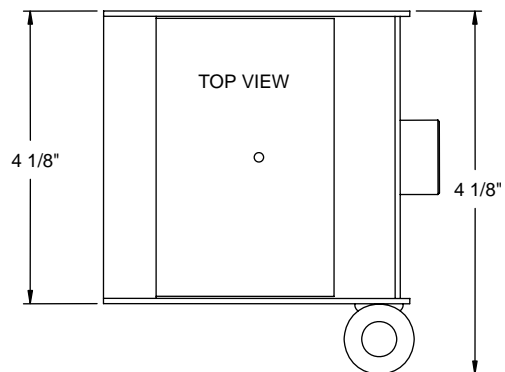
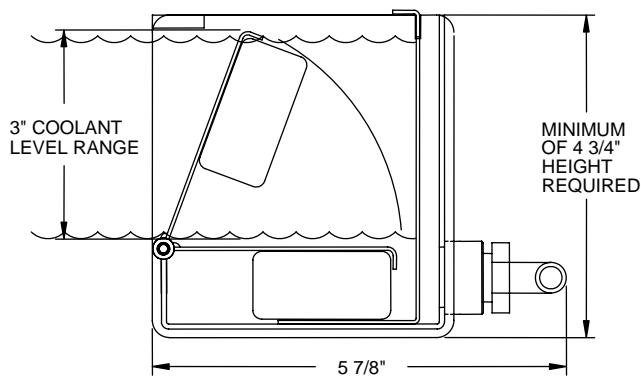

SHALLOW DRAFT SKIMMER BOX DIMENSIONS

Manufactured in U.S.A. by:

Design & Manufacturing, Inc.

www.design-mfg.net
or phone 800/236-9496

