

SKIMERATOR® MODEL 3200D SPECIFICATIONS

Basic system includes deep draft skimmer with screen, skimmer box stand, electric pump, reservoir with baffle assembly and weir box assembly, flow restrictor and all necessary hoses and fittings.

- Use in sumps where the coolant level varies No more than 5".
- Accommodates a coolant depth of 2" to 7" (with skimmer box on floor of sump) and 2-3/4" to 18-1/4" using the adjustable skimmer foot and post.

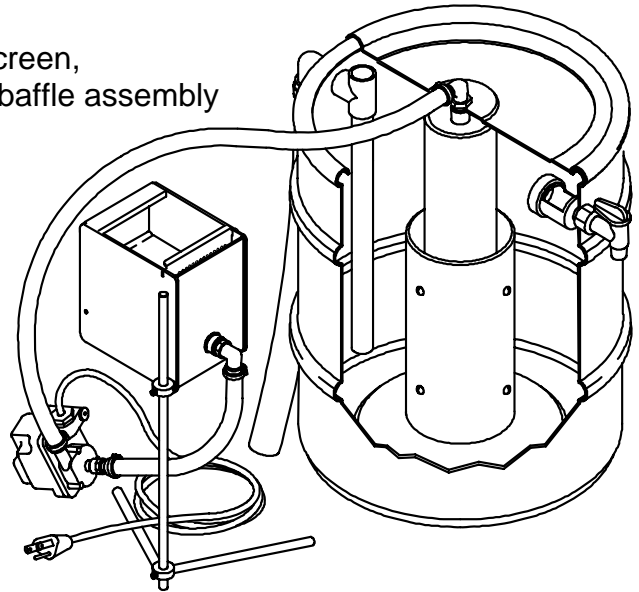

See Skimerator manual PIB 3241 for more information.

SPECIFICATIONS

Pump specifications	Submersible, epoxy encapsulated motor, 115v, 1/125 HP. 10' cord.
Pump capacity	100 GPH (5' height) to 140 GPH (3' height) @3 PSI, 120 deg. max.
Reservoir	Translucent polyethylene, 15 gallon capacity, 16" dia x 21" high.
Warranty	12 months parts and labor

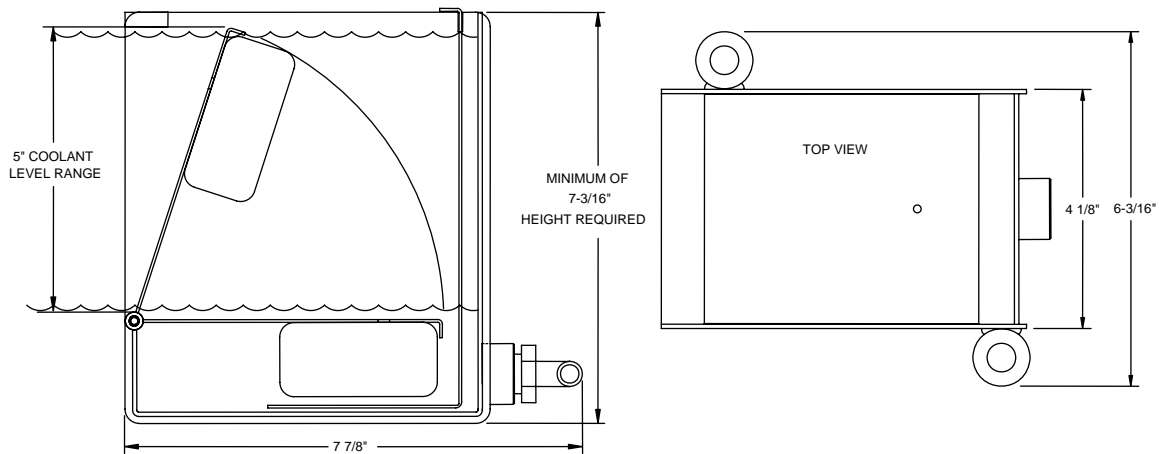

DEEP DRAFT SKIMMER BOX DIMENSIONS

Manufactured in U.S.A. by:

Design & Manufacturing, Inc.

www.design-mfg.net
or phone 800/236-9496

